

**! CAUTION !**

Cuts, injuries and/or fire may result from non-compliance with all operating procedures described within this instruction manual.



**ATTENTION:**

If any components of this unit are broken,  
or if the unit does not operate properly,  
please contact LEM Products at

**1-877-536-7763**

For more great products or a free catalog  
log onto [www.lemproducts.com](http://www.lemproducts.com)

THE LEADER IN GAME PROCESSING



# 8 1/2" MEAT SLICER

**USE & MAINTENANCE**

1164



**1 YEAR  
WARRANTY**

**! CAUTION !**

Cuts, injuries and/or fire may result from non-compliance with all operating procedures described within this instruction manual.

**▲ WARNING! SHARP BLADE ▲**

**HANDLE CAREFULLY! KEEP FINGERS AWAY FROM THE CUTTING BLADE!  
NEVER FEED FOOD BY HAND! ALWAYS USE THE FOOD PUSHER!**

Always use completely assembled meat slicer with sliding food carriage and food pusher.  
Protective/cut resistant gloves are recommended whenever handling blade!



**CAUTION**



**Before using the slicer for the first time please make sure to read carefully and thoroughly through these operating instructions and the safety advice. Familiarize yourself completely with the functions of the appliance.**

## **⚠ GENERAL WARNINGS AND SAFETY INFORMATION ⚠**

1. Always ensure that the slicer is properly assembled and safely set up before use.
2. **DO NOT** leave the slicer unattended if it can be switched on and operated.
3. **CAUTION:** This appliance is not recommended for use near or by children or persons with certain disabilities. Set up and store the slicer out of reach of children. When not in use disconnect the slicer from power source. Store the device in a secure and dry place out of reach of children. Do not allow children to operate the slicer.
4. **CAUTION:** Exposed sharp metal blade! Use Extreme Caution when handling and cleaning metal blade. Do not touch sharp edge of the blade. It is recommended that cut resistant gloves be worn when handling the blade. Never touch the blade when the slicer is in use.
5. Thoroughly hand-wash all removable slicer parts with warm, soapy water prior to use. Do not soak. **NOT DISHWASHER SAFE** (discoloration may occur).
6. To avoid injury, never hand feed food to be sliced. Sliding feed table and food pusher should always be in place during use.
7. **CAUTION: NEVER PUT YOUR FINGERS NEAR THE BLADE WHILE IT IS IN OPERATION.**
8. The slicer must be connected to a 120V AC electric supply only.
9. This appliance has a polarized plug (one blade is wider than the other). To reduce the risk of electric shock, this plug will fit in a polarized outlet one way. If the plug doesn't fit fully into the outlet, reverse the plug. If it still does not fit, contact a qualified electrician. **DO NOT** modify the plug in any way.
10. **DO NOT** operate with a damaged cord or plug, after the unit malfunctions, has been damaged in any way or if appliance has been immersed in water or other liquid. Return unit to LEM Products for assessment and repair.
11. Always unplug unit when not in use, when changing parts or cleaning.
12. Never unplug by pulling on the power cord, always pull directly on the plug itself.
13. **DO NOT** let cord hang over edge of table or counter, contact sharp edges or touch hot surfaces.
14. Use the appliance on a level, stable surface to prevent tipping. Never move the appliance while unit is in use.
15. Indoor use only. To protect against the risk of electrical shock, never immerse the device in water and do not expose the device to rain or moisture. **WARNING: In the event the device should fall into water, remove the plug from the wall socket before attempting to remove the unit from the water.** If submergence occurs, have the slicer examined by an authorized technician before use.
16. To protect against the risk of electrical shock, **DO NOT** use the slicer if your hands are wet or if you are standing on a wet floor. **DO NOT** use the slicer if it is wet or moist. **DO NOT** operate this device with wet hands or bare feet. **DO NOT** operate near running water.
17. The slicer is designed exclusively for domestic use and not for commercial purposes.
18. **DO NOT** use the slicer to slice through bones, frozen food or non-food items.
19. Use the slicer with the supplied accessories only. **WARNING: The use of attachments not recommended or sold by the manufacturer may cause injury, damage to personal property, and may void your warranty.**
20. **WARNING: DO NOT** use while under the influence of alcohol or drugs (prescription or non-prescription) as these may impair user's ability to properly assemble or safely operate the slicer.
21. The manufacturer declines any responsibility in the case of improper use of this product. Improper use of this product voids the warranty.
22. Warning: Blade continues to spin after slicer has been turned off. Wait until all moving parts have stopped before removing any part of the slicer.
23. Always unplug the slicer from the power source prior to servicing, changing accessories, or cleaning the unit.
24. To reduce risk of unintentional starting, make sure the power switch is in the off position before unit is plugged into the power source.
25. Tie back loose hair and clothing and roll up long sleeves before operating the slicer. Remove ties, rings, watches, bracelets or other jewelry before operating the slicer.
26. Avoid danger or injury by only using the slicer fully assembled. Ensure Blade Locking Screw is properly engaged and tightened prior to use.

## **IMPORTANT WARRANTY INFORMATION PLEASE READ FILL OUT AND RETURN ENCLOSED WARRANTY CARD**

THIS WARRANTY COVERS

THE LEM 1164: 8 1/2" MEAT SLICER

THE WARRANTY IS EXTENDED TO THE ORIGINAL PURCHASER ONLY.

**WARRANTY DURATION:** This product is warranted to the original purchaser for a period of one (1) year from the original purchase date. **EACH UNIT COMES WITH A WARRANTY CARD, WHICH MUST BE FILLED OUT COMPLETELY AND RETURNED IMMEDIATELY, WITH A COPY OF THE PURCHASING RECEIPT. FAILURE TO RETURN YOUR WARRANTY CARD WILL LIMIT WARRANTY TO 90 DAYS WITH PROOF OF PURCHASE.**

**WARRANTY COVERAGE:** This product is warranted against defective materials or workmanship. The warranty is void if the product has been damaged by accident, misuse, neglect, modification or improper service or repairs by unauthorized personnel. It is also void if damaged in shipment or by other causes not arising out of defects in the materials or workmanship. This warranty does not extend to any units which have been in violation of written instructions furnished.

**WARRANTY DISCLAIMERS:** This warranty is in lieu of all warranties expressed or implied, and no representative or person is authorized to assume any other liability in connection with the sale of our products. There shall be no claims for defects or failure of performance under any theory of sort, contract or commercial law including, but not limited to negligence, gross negligence, strict liability or breach of contract. The manufacturer declines all responsibility for damage to persons, things or animals arising from the failure to comply with the norms contained in this manual. The manufacturer reserves the right to make modifications at anytime to the models while maintaining the main characteristics described herein. The manufacturer also declines all responsibility for any errors in compiling this manual.

**WARRANTY PERFORMANCE:** During the above one year warranty period, a product with a defect will either be repaired or replaced after the product has been inspected by an LEM Service Technician. **LEM RESERVES THE RIGHT TO REFUSE WARRANTY PERFORMANCE OR PRODUCT EVALUATION UNLESS THE ORIGINAL SALES RECEIPT OR THE WARRANTY CARD IS ON FILE.** The repaired product will be in warranty for the balance of the one year warranty period. No charge will be made for such repair or replacement.

**IMPORTANT NOTICE:** If any parts are missing or defective, please contact our Customer Service Department for assistance at **877-536-7763. (M-F 8:30am to 4:30pm EST) DO NOT RETURN TO THE STORE WHERE THE PRODUCT WAS PURCHASED.**

### **LEM PRODUCTS MERCHANDISE RETURN POLICY WARRANTY SERVICE:**

To obtain service under terms of this warranty, please contact us at 877-536-7763 to obtain authorization prior to returning the merchandise. No merchandise will be accepted without prior authorization. Please return the product pre-paid in the original packaging if possible, enclose a copy of your receipt, (Keep a copy of your proof-of purchase for your records.) and include a written explanation of the issue. Ship to LEM Products, 4440 Muhlhauser Rd., suite 300, West Chester, OH 45011. LEM Products is not responsible for damage incurred in shipping, make certain to pack product properly. Return shipping charges are the responsibility of the purchaser. Packages returned to LEM should be insured for the value of the product to cover any damages that may occur during shipping.

Revised May 14, 2014

## STORAGE

**SWITCH POWER TO "OFF" POSITION, UNPLUG SLICER FROM OUTLET AND SET THICKNESS ADJUSTMENT KNOB TO "P" SETTING.**

**Note: Always align Sliding Feed Table with the Blade for safety and blade protection during storage and maintenance. This is accomplished by returning the Thickness Adjustment Knob to the "P" position.**

- Unplug slicer and allow it to cool completely before storing.
- Align Sliding Feed Table with the Blade for safety and blade protection during storage and maintenance. This is accomplished by returning the Thickness Adjustment Knob to the "P" position.
- Store slicer in a secure and dry place out of reach of children.
- Slicer should be stored unplugged, in upright position on a stable surface, preferably in the original packaging.

## SLICER USAGE

### Uses For Your Food Slicer

#### For best results follow these tips:

- To slice meat wafer thin, meat should be firm but not throughly frozen.
- Meat should be boneless. Fruit should be free of pits and large seeds.
- Food with an uneven texture-like fish and thin steaks –are often difficult to slice. Freeze for 2 to 4 hours so food is firm before slicing.
- At canning time, slicer can quickly cut cucumbers, onions or other vegetables or fruits for delicious pickles... apples pies...vegetables.

#### HOT ROASTS: BEET, PORK, LAMB, HAM

- When slicing warm boneless roast, remove from oven at least 15 to 20 minutes before slicing. The roast will retain more natural juices and slice evenly without crumbing.
- Cut the roast, if necessary, to fit on Food Tray. If roast is tied, turn off motor and remove strings one at a time as strings near blade.

#### EXTRA-THIN SLICED CORNED BEEF OR FRESH BEEF BRISKET

Chill cooked brisket overnight in cooking liquid. Before slicing, drain and reserve meat drippings from brisket. Pat dry with paper towels. Remove excess fat. Slice well chilled brisket to desired thickness. To serve hot, place slices on heat proof platter and moisten with small amount of reserved meat dripping. Heat in 300° oven for 30 minutes.

#### CHEESE

Chill thoroughly before slicing. Cover with foil to keep moist. Before serving, let cheese reach room temperature-this enhances the natural flavor.

#### COLD CUTS

Cold cuts keep longer and retain flavor if sliced as needed. For best results, chill first. Remove any plastic or hard casing before slicing. Use a constant, gentle pressure for uniform slices.

#### VEGETABLE AND FRUIT

Your slicer is "made to order" for slicing many vegetables and fruits including potatoes, tomatoes, carrots, cabbage (for slaw), eggplant, squash and zucchini. Potato may be sliced thick for casseroles or thin for chips. Fresh pineapple may be sliced neatly. Cut off top and slice to order.

#### BREADS, CAKES AND COOKIES

Freshly baked bread should be cooled before slicing. Use day-old or slightly stale bread for extra-thin slices for toasting. Your slicer is ideal for all types of party breads, pound cake and fruit cake. For wafer-like ice box cookies, chill dough in refrigerator, slice as desired.

## ⚠ WARNING! SHARP BLADE ⚠

**HANDLE CAREFULLY! KEEP FINGERS AWAY FROM THE CUTTING BLADE!**

**NEVER FEED FOOD BY HAND! ALWAYS USE THE FOOD PUSHER!**

**Always use completely assembled meat slicer with sliding food carriage and food pusher.**

**Protective/cut resistant gloves are recommended whenever handling blade!**

## ⚠ CAUTION ⚠

**Before cleaning, assembling or disassembling meat slicer, make sure the slicer motor is OFF and the plug is removed from the outlet/power source.**

## KNOW YOUR SLICER

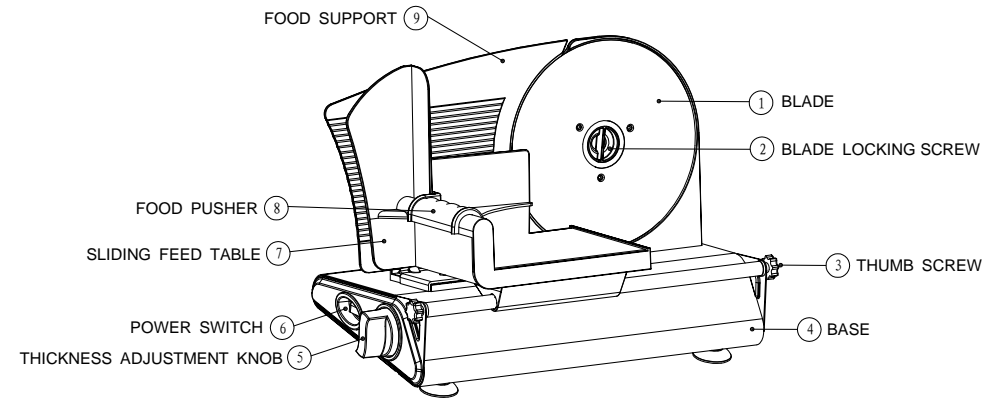

### SLICER SPECIFICATIONS

**Power:** 120V

**Power Rating:** 150W

**Slice Thickness:** 0mm - 15mm / .6"

**Blade Size:** 220mm Dia., Reinforced, Stainless Steel Fine and Serrated Blades

## SLICER OPERATING INSTRUCTIONS

**Before using the slicer for the first time, please make sure to read carefully and thoroughly through these operating instructions and safety advice. Familiarize yourself completely with the functions and operations of the slicer. Please keep these instructions with your slicer and make sure that everyone who will be operating the slicer has read them.**

**This slicer is intended exclusively for slicing normal household foods. The food to be sliced must be thawed, unpacked and free from bones before it can be sliced. Any other use or modification to the equipment shall be considered as improper use and could give rise to considerable dangers.**

## ⚠ **WARNING! SHARP BLADE** ⚠

**HANDLE CAREFULLY! KEEP FINGERS AWAY FROM THE CUTTING BLADE!**

**NEVER FEED FOOD BY HAND! ALWAYS USE THE FOOD PUSHER!**

**Always use completely assembled meat slicer with sliding food carriage and food pusher.**

**Protective/cut resistant gloves are recommended whenever handling blade!**

**To avoid injury never hand feed food to be sliced. Sliding feed table and food pusher should always be in place during use.**

## **PREPARING TO SLICE**

1. Carefully remove slicer from packaging. Clean the slicer before it comes into contact with any food. (refer to section "Cleaning and Maintenance")
2. Determine proper Blade for use, smooth Blade for fine deli cuts, serrated for breads and thick cuts. (refer to section "Cleaning and Maintenance" for blade changing instructions)
3. Position slicer on a clean, dry and smooth surface.
4. Move the Sliding Feed Table back and forth a few times to ensure movement. If Feed Table does not slide freely oil Sliding Bar with a little food grade lubricant (mineral oil, food grade grease, vegetable oil.)
5. Place the Food Pusher on back of the Sliding Feed Table.
6. Select the required slice thickness by turning Thickness Adjusting Knob. The range of thickness adjusting is from 0 to 15mm.

## **SLICER USAGE AND OPERATION**

1. Place the slicer on a dry, stable, flat surface.
2. Ensure the Power Switch is in the "off" position.
3. Ensure the Thickness Adjustment Knob is in the "P" position.
4. Connect the Power Cord into a 120v outlet.
5. Move Sliding Food Tray away from the blade. Place food to be sliced on Food Tray and position Food Pusher behind food. (Maximum size of food is 4 1/4" x 4 1/4" x 3 1/2" LxWxD).

### **KEEP FINGERS AWAY FROM BLADE AT ALL TIMES**

6. Rotate Thickness Adjustment Knob to desired cutting thickness.
7. Turn Power Switch to "on". Blade will begin to turn.
8. Hold and gently press the Food Pusher towards the food and ensure all fingers are safely behind the protective handles.
9. Begin slicing while gently pushing the food towards the Food Plate and sliding the Food Table towards the Blade. Allow the turning of the Blade to do the slicing. Do not attempt to make the slicer work faster than it is intended. Doing so will bog down the motor and tear the product you are attempting to slice.
10. Steadily move the Food Table back and forth in a slow smooth motion.
11. Do not operate the slicer for longer than 5 minutes at a time or unit may overheat. Turn Power Switch to "off", unplug slicer, and allow unit to cool for 30 minutes.
12. When slicing is complete, switch power to "off" and the Thickness Adjustment Knob to "P".

Note: It is best to position yourself on the left side of the slicer. LEM suggests turning the slicer so it sits at a 90 degree angle from the front of the counter. Doing this will give more leverage and it will be easier to slice food from this position.

## ⚠ **WARNING! SHARP BLADE** ⚠

**HANDLE CAREFULLY! KEEP FINGERS AWAY FROM THE CUTTING BLADE!**

**NEVER FEED FOOD BY HAND! ALWAYS USE THE FOOD PUSHER!**

**Always use completely assembled meat slicer with sliding food carriage and food pusher.**

**Protective/cut resistant gloves are recommended whenever handling blade!**

## ⚠ **CAUTION** ⚠

**Cuts, injuries and/or fire may result from non-compliance with all operating procedures described within this instruction manual.**

**Before starting to clean slicer, switch unit "OFF", remove unit from power source and set Thickness Adjustment Knob to "P". Never immerse the slicer in water.**

## **CLEANING AND MAINTENANCE**

**SWITCH POWER TO "OFF" POSITION AND UNPLUG SLICER FROM OUTLET AND SET THICKNESS ADJUSTMENT KNOB TO "P" SETTING.**

**Note: Always align Sliding Feed Table with the Blade for safety and blade protection during storage and maintenance. This is accomplished by returning the Thickness Adjustment Knob to the "P" position.**

**CAUTION:** Blade is sharp! LEM suggests wearing cut resistant gloves when removing or replacing Blade.

- Unplug and allow slicer to cool completely.
- Remove the Food Pusher by simply lifting it off the Feed Table handle.
- Remove the Sliding Feed Table by unscrewing the Thumb Screws that are located on the ends of the Sliding Bar. This will release the Sliding Bar and allow for easy clean up of the Sliding Feed Table and the Base of the slicer.
- Remove the Blade; loosen the Blade Locking Screw by turning in a clockwise direction. After cleaning, tighten the Blade with the Blade Locking Screw by turning it in a counterclockwise direction.
- Wash all removable parts in hot soapy water. Rinse and dry.
- Wipe slicer body and base with a damp cloth. Do not use abrasive cleaning agents or materials.
- Feet can be cleaned with a gentle grease removing cleanser, such as alcohol or window cleaner.

**STAINLESS BLADE:** Unplug the slicer, loosen the Blade Locking Screw by turning clockwise, as the arrow direction indicates. Then, wearing a glove, carefully take off the Blade. After cleaning, tighten the Blade with the Blade Locking Screw in the counter clockwise direction.

**Note: Always align Food Support Table with blade by returning the thickness adjustment knob to the "P" position, for safety and blade protection during storage and maintenance.**