



## #10 Cast Iron Electroplated Hand Operated Meat Grinder #058

### PERFORMANCE AND SPECIFICATION

This meat grinder is an ideal kitchen appliance with compact construction, modern style, convenient operation and a high output rate—2-3 pounds per minute.

### Warning

- Do not put your fingers into the mouth of the grinder, while grinding. Use appropriate tool to push meat into grinder.
- Do not attempt to grind large bones.
- Assemble the machine according to the diagram.

PART#	DESCRIPTION	QTY. PCS.
1	Retaining Ring	1
2	10 MM Plate 3/8"	1
3	4.5 MM Plate 3/16"	1
4	Knife	1
5	Auger Stud	1
6	Worm Gear / Auger	1
7	Bushing	1
8	Body / Head	1
9	Handle Arm	1
10	Handle Screw	1
11	Handle	1
12	Handle Bolt	1
13	Rubber Pad	1
14	Locking Screw Cover	1
15	Locking Screw	1
16	Stuffing Tubes 7/8", 3/4", 1/2"	3

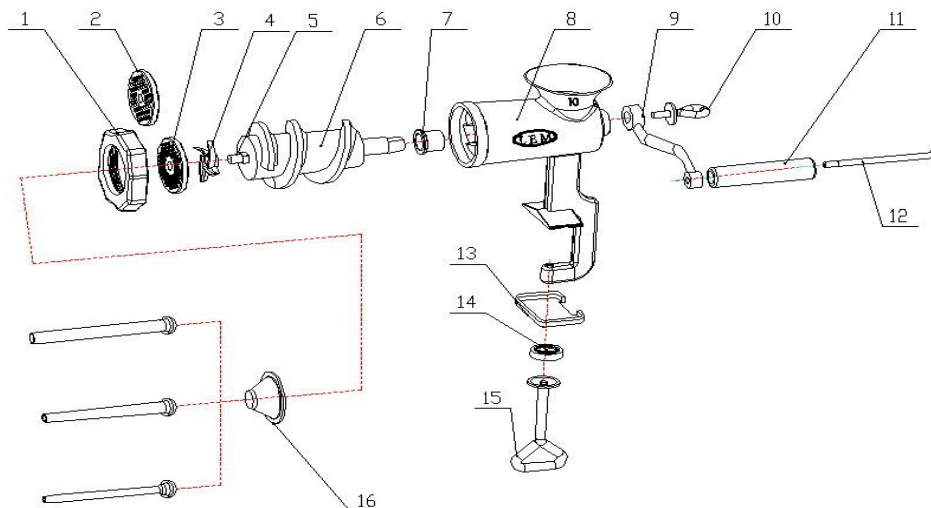



### **Directions for using your LEM Products Hand Grinder #058**

Hand-wash all parts of the grinder in hot soapy water to remove the protective oil coating on the grinder and its parts. Rinse with hot water and dry thoroughly. Do not place any part of the grinder in a dishwasher.

Bolt the grinder head (#8) to a sturdy board that can be easily cleaned. After the grinder head is fastened to the board, the board can be clamped or screwed to a sturdy bench or table. Attach the auger stud (#5) to the worm gear/auger (#6). Take the worm gear/auger (#6) and slide it all the way into the head (#8) until it meshes with the square shaft in the back of the unit. Using the handle screw (#10), attach the handle arm (#9) to the shaft of the auger. Next put the grinder knife (#4) onto the square portion of the auger stud on the end of the worm gear/auger (#6). Make sure the sharp edges of the knife are facing out toward the grinder plate. Now put a grinder plate (#2) on the auger stud square shaft, then attach the retaining ring (#1).

Using the coarse plate (#2) with the  $\frac{3}{8}$ " holes for the first grind. Slide the plate onto the stud and push it up against the grinder knife. Make sure the notch in the plate is aligned with the locator pin on the grinder head. Screw the large retaining ring (#1) onto the end of the grinder head. Hand-tighten the retaining ring. After grinding, remove the  $\frac{3}{8}$ " plate and clean out any sinew or fat in the grinder. For the second grind, use the fine plate (#3) with the  $\frac{3}{16}$ " holes.

Over-tightening the retaining ring will cause excessive wear on the knife and plate of the grinder. Under tightening will cause the meat to be mashed instead of cut. If mashing occurs, disassemble the grinder, clean out the meat from the grinder and plate, reassemble the grinder and tighten the ring a little tighter than it was originally.

After using the grinder, disassemble and hand wash in hot soapy water. Rinse with hot water and dry thoroughly. Do NOT let air-dry. After drying, coat the head, worm gear, knife and plates with a food grade silicone spray. This will prevent oxidation and keep the unit in good operating condition for many years of dependable service. L.E.M. Products recommends that you use our Silicone Spray. It is USDA approved and complies with FDA regulations.

When making burger from wild game, add a minimum of 10% pork fat to the meat. This will give the burger moisture, but not make it fatty. If pork fat is not available, use beef fat. Never use beef suet. Suet is too hard. The burger will be cooked before the suet melts causing suet particles to remain in the burger.

When making sausage, add at least 20% fat with the meat and grind it like burger. Mix the seasoning with the meat after the first grind and then grind the mixture a second time. For a coarser texture, grind the meat through the  $\frac{3}{16}$ " plate one time. Then mix the seasoning with the meat. This works well for those who like coarse sausage. Also, L.E.M. Products recommends that you use our Soy Protein when making sausage. It is available in a 1lb. package, which is enough to make 50 lbs. of meat. Use 2 teaspoons of Soy Protein for each pound of meat. Soy Protein helps to retain moisture and prevent shrinking during smoking or cooking. It is very high in protein making it an excellent binder, and gives the finished sausage a smooth, moist consistency. Soy Protein has no taste. It contains no cholesterol and is fat free because it is derived from a vegetable source.

#### **CASINGS**

L.E.M. Products carries both natural sheep and natural hog casings in hanks and also beef Rounds. Fresh casings produce a juicy, tender sausage. You'll hear a distinctive 'pop' when you bite into a sausage stuffed in a natural casing. To store unused casings, cover the casings with salt, place them in a zip lock bag and refrigerate. The casings will keep for an indefinite length of time. Natural casings produce 4-5 links per pound. Salted casings have a very long shelf life. Not refrigerated, the salted casings quickly give off a strong odor even though they are not spoiled. Put them back under refrigeration and for the most part the odor disappears. To use natural casings, rinse them in cold water several times, flush the inside, then soak in water for about 1 hour until they become soft and pliable.

When putting the casing on a stuffing tube, place it loosely on the tube. If it does not go on easily, the tube is too large. Forcing the casing onto a tube that is too large will cause breakage and it may not come off the tube correctly. Sausage meat should be stuffed as tightly as possible into the casing.

Collagen casings are uniform in size for easier stuffing. They can be used for fresh or smoked sausage. The smoked collagen casings are stronger than the fresh collagen casings so they can be hung in a smoker and not break. DO NOT soak collagen casings before stuffing.

Synthetic/Fibrous Casings can be used for summer sausage, hard salami, trail bologna, sweet bologna and many other sausages. They should be soaked in warm water for 20 – 30 minutes before stuffing.

Large synthetic casings should be stuffed one section at a time. Hold the casing firmly on the tube. Pack the meat tightly into the casing to prevent air pockets. After stuffing the casing, grab the untied end with one hand and the tied end with the other hand. Twist the untied end of the stuffed casing closed until the log becomes very firm. This next step may take 2 people. One person can hold the twisted filled casing and the other person can tie the open end closed. You can also use hog rings to close the open end of the casing. Hog rings and pliers are available at L.E.M. Products. Inspect the stuffed casings for air pockets. Lightly puncture as many air pockets as possible to avoid fat reservoirs from forming in the pockets while cooking.

For all types of sausage seasonings, casings and other meat processing equipment see your local dealer or call LEM Products toll free at 877-536-7763. Or visit our web site [www.lemproducts.com](http://www.lemproducts.com).