

**IMPORTANT WARRANTY INFORMATION PLEASE READ
FILL OUT AND RETURN ENCLOSED WARRANTY CARD**

THIS WARRANTY COVERS:
LEM Ground Meat Packing System #200
LEM Poly Bag Tape Machine #W043
THE WARRANTY IS EXTENDED TO THE ORIGINAL PURCHASER ONLY

WARRANTY DURATION: This product is warranted to the original purchaser for a period of one (1) year from the original purchase date. **EACH UNIT COMES WITH A WARRANTY CARD, WHICH MUST BE FILLED OUT COMPLETELY AND RETURNED IMMEDIATELY, WITH A COPY OF THE PURCHASING RECEIPT. FAILURE TO RETURN YOUR WARRANTY CARD WILL LIMIT WARRANTY TO 90 DAYS WITH PROOF OF PURCHASE.**

WARRANTY COVERAGE: This product is warranted against defective materials or workmanship. The warranty is void if the product has been damaged by accident, misuse, neglect, modification or improper service or repairs by unauthorized personnel. It is also void if damaged in shipment or by other causes not arising out of defects in the materials or workmanship. This warranty does not extend to any units which have been in violation of written instructions furnished. This warranty covers only the product and its specific parts, not food or other products processed in it.

WARRANTY DISCLAIMERS: This warranty is in lieu of all warranties expressed or implied, and no representative or person is authorized to assume any other liability in connection with the sale of our products. There shall be no claims for defects or failure of performance under any theory of sort, contract or commercial law including, but not limited to negligence, gross negligence, strict liability or breach of contract. The manufacturer declines all responsibility for damage to persons, things or animals arising from the failure to comply with the norms contained in this manual. The manufacturer reserves the right to make modifications at anytime to the models while maintaining the main characteristics described herein. The manufacturer also declines all responsibility for any errors in compiling this manual.

WARRANTY PERFORMANCE: During the above one year warranty period, a product with a defect will either be repaired or replaced after the product has been inspected by an LEM Service Technician. **LEM RESERVES THE RIGHT TO REFUSE WARRANTY PERFORMANCE OR PRODUCT EVALUATION UNLESS THE ORIGINAL SALES RECEIPT OR THE WARRANTY CARD IS ON FILE.** The repaired product will be in warranty for the balance of the one year warranty period. No charge will be made for such repair or replacement.

IMPORTANT NOTICE: If any parts are missing or defective, please contact our Customer Service Department for assistance at 877-536-7763 (M-F 8:30am to 4:30pm EST). **DO NOT RETURN TO THE STORE WHERE THE PRODUCT WAS PURCHASED.**

LEM PRODUCTS MERCHANDISE RETURN POLICY WARRANTY SERVICE: To obtain service under terms of this warranty, please contact us at 877-536-7763 to obtain authorization prior to returning the merchandise. No merchandise will be accepted without prior authorization. Please return the product prepaid in the original packaging if possible, enclose a copy of your receipt, (keep a copy of your proof-of-purchase for your records) and include a written explanation of the issue. Ship to LEM Products, 4440 Muhlhauser Road, Suite 300, West Chester, OH 45011. LEM Products is not responsible for damage incurred in shipping, make certain to pack product properly. Return shipping charges are the responsibility of the purchaser. Packages returned to LEM should be insured for the value of the product to cover any damages that may occur during shipping.

Revised November 20, 2015

THE LEADER IN GAME PROCESSING



GROUND MEAT PACKING SYSTEM

USE & MAINTENANCE

200 & W043



**1 YEAR
WARRANTY**

⚠ GENERAL WARNINGS AND SAFETY INFORMATION ⚠

IT IS IMPORTANT TO READ AND UNDERSTAND ALL OF THE INSTRUCTIONS AND SAFEGUARDS PRIOR TO USE

1. Always ensure that the appliance is properly assembled and safely set up before use.
3. **CAUTION:** This appliance is not recommended for use near or by children or persons with certain disabilities. Set up and store the appliance out of reach of children. When not in use, store device in a secure and dry place out of reach of children.
15. The appliance is designed for domestic use and not for commercial purposes.
17. Use the appliance with the supplied accessories only. **WARNING:** The use of attachments not recommended or sold by the manufacturer may cause injury, damage to personal property, and may void your warranty.
18. **WARNING:** Do not use while under the influence of alcohol or drugs (prescription or non-prescription) as these may impair user's ability to properly assemble or safely operate the appliance.
19. The manufacturer declines any responsibility in the case of improper use of this product. Improper use of this product voids the warranty.
23. Thoroughly hand-wash all parts in warm soapy water prior to use. **DO NOT SOAK. NOT DISHWASHER SAFE** (discoloration may occur).
24. Tie back loose hair and clothing. Remove neckties, rings, watches, bracelets or other jewelry before operating.
25. Use on a level, stable surface to prevent tipping. Never move the appliance while in use.
26. **WARNING:** Blade is **SHARP!** To avoid injury, use extreme caution when handling.
28. **SAVE THESE INSTRUCTIONS**

PARTS LIST

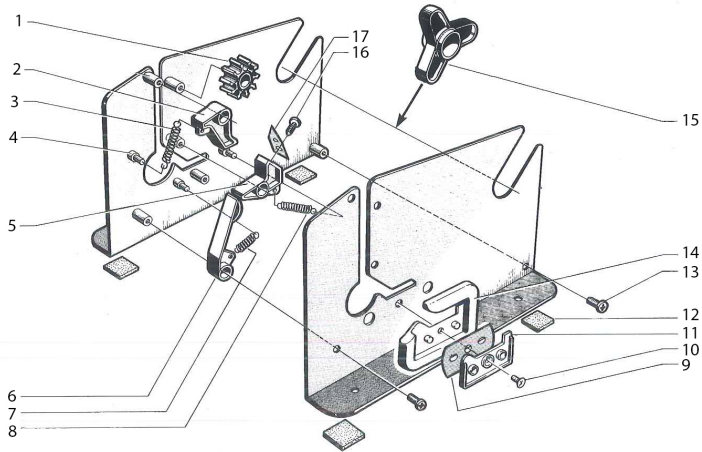

Part #	Discription
1	Tape Thread Wheel
2	Tape Thread Holder
3	Tape Thread Holder Spring
4	Spring Mount
5	Blade Holder
6	Break
7	Break Spring
8	Blade Holder Spring
9	Trim Blade

Part #	Discription
10	Trim Blade Screw
11	Trimmer Set Front Plate
12	Rubber Feet
13	Housing Screw
14	Trimmer Set Back Plate
15	Tape Holder
16	Cutting Balde Screw
17	Cutting Blade

HOW TO USE

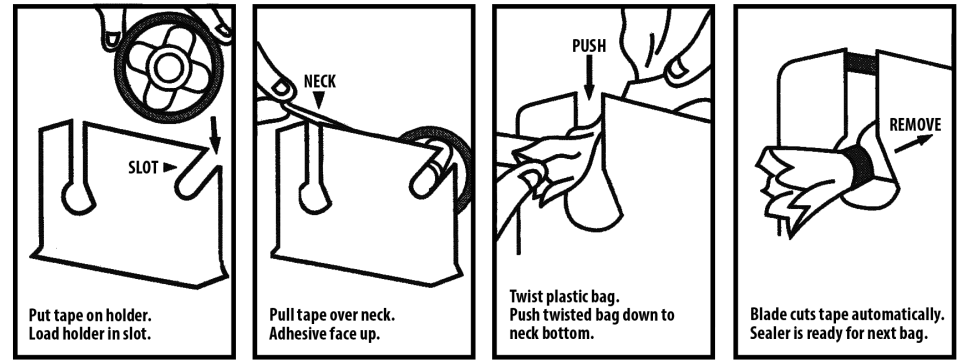

To Load Tape Machine: Insert tape on machine and pull about 6 inches off the roll with the sticky side up. Lay the tape over the slot in the machine. That's it! When you push a bag into the slot, the tape will go into the slot and the tape will seal the bag and be cut off.

To Fill Ground Meat Bags: Grind meat through the coarse plate once. Change the coarse plate to the fine plate. Put a stuffing tube over the fine plate and tighten the grinder hub. Slide a meat bag over the stuffing tube. As you grind with the fine plate, the meat will go directly through the tube and into the bag. Hold back a little on the bag as it fills to minimize the amount of air in the bag and to pack the meat tightly. (Air pockets promote freezer burn.) Twist the bag at the top and insert the twisted portion down into the slot of the tape machine pushing down briskly through the slot. The machine will apply a tape strip to the twisted bag. That's all there is to it! Lay bags in the freezer one layer high. The bags can be stacked, once they are thoroughly frozen. Stacking the bags before they are thoroughly frozen will prevent them from freezing quickly.

Ask the dealer where you purchased this item for additional supplies of tape, bags and other food processing equipment. Also available is a 2-inch stuffing tube designed to make filling ground meat bags or large casings easy. The grinder stuffing tubes are available from your dealer of LEM Products.