



ATTENTION:
If any components of this unit are broken,
or if the unit does not operate properly,
please contact LEM Products at
877-536-7763
Find more great products and request a
free catalog at lemproducts.com

Scan our QR code
for more information
and helpful videos



BIG BITE[®] **ELECTRIC MEAT GRINDER**

USE & MAINTENANCE

1781, 1782



**5 YEAR
WARRANTY**



IMPORTANT SAFETY INFORMATION



WARNING

Keep children away from this grinder! Turn off and unplug when not in use.

IT IS IMPORTANT TO READ AND UNDERSTAND ALL OF THE INSTRUCTIONS AND SAFEGUARDS PRIOR TO USE.

SAVE THIS MANUAL

Every user must read and fully understand this manual and its contents, especially the Important Safety Information, before using or operating the appliance. This manual must accompany this appliance.

Questions? Call LEM Products technical assistance toll-free: (877) 536-7763

General Safety Information

- Use the appliance only for its intended use. Indoor use only. Household use only. Improper use of this appliance voids the warranty.
- This appliance is not intended for use by persons (including children) with reduced physical, sensory, or mental capabilities, or lack of experience and knowledge, unless they have been given supervision or instruction concerning use of the appliance by a person responsible for their safety. Children should be supervised to ensure that they do not play with the appliance.
- Knife and plates are sharp! To avoid injury, use caution when handling.
- Grinder is heavy; use proper lifting techniques when moving to avoid muscle strain or back injury.
- Do not use while under the influence of alcohol or prescription or non-prescription drugs as these may impair your ability to properly assemble or safely operate the appliance.
- Use the appliance with supplied accessories only. The use of accessories or attachments not recommended or sold by the manufacturer may cause injury, damage to personal property and may void your warranty.
- Do not attempt to disable any of the safety features that are in place. They are there for your safety. The manufacturer declines any responsibility in the case of improper use of this appliance.
- Splintered bones can get into the digestive tract of a pet and cause severe damage, or even death, by puncturing the walls of the intestines or the stomach.
- Read all warnings and instructions in this manual. In addition, use common sense; your personal safety is your responsibility. Failure to follow warnings and safety information could result in death, serious bodily injury, and/or property loss.

Safety Information Before Use

- Always ensure that the appliance is properly assembled and safely set up before use. Set up and store the appliance out of reach of children. It is important to monitor the appliance when in use. Never leave the appliance unattended if it can be switched on and operated.
- Use appliance on a level, stable surface to prevent it from overturning and possibly causing injury and/or damage to appliance. Never move the appliance while it is in use.
- Tie back loose hair and clothing to prevent them from getting caught in moving parts and causing injury. Remove neckties, rings, watches or other jewelry before operating the grinder.

Safety Information During Use

- Avoid contacting moving parts to prevent injury. Turn off grinder and unplug and then wait until all parts have come to a complete stop and disconnect from the power source before removing any parts of the grinder.

IMPORTANT WARRANTY INFORMATION PLEASE READ FILL OUT AND RETURN ENCLOSED WARRANTY CARD

THIS WARRANTY COVERS:

LEM 1700 Series **Big Bite**® Grinders

THE WARRANTY IS EXTENDED TO THE ORIGINAL PURCHASER ONLY

WARRANTY DURATION: This product is warranted to the original purchaser for a period of five (5) years from the original purchase date. **EACH UNIT COMES WITH A WARRANTY CARD, WHICH MUST BE FILLED OUT COMPLETELY AND RETURNED IMMEDIATELY, WITH A COPY OF THE PURCHASING RECEIPT. FAILURE TO RETURN YOUR WARRANTY CARD WILL LIMIT WARRANTY TO 90 DAYS WITH PROOF OF PURCHASE.**

WARRANTY COVERAGE: This product is warranted against defective materials or workmanship. The warranty is void if the product has been damaged by accident, misuse, neglect, modification or improper service or repairs by unauthorized personnel. It is also void if damaged in shipment or by other causes not arising out of defects in the materials or workmanship. This warranty does not extend to any units which have been in violation of written instructions furnished. This warranty covers only the product and its specific parts, not food or other products processed in it.

WARRANTY DISCLAIMERS: This warranty is in lieu of all warranties expressed or implied, and no representative or person is authorized to assume any other liability in connection with the sale of our products. There shall be no claims for defects or failure of performance under any theory of tort, contract or commercial law including, but not limited to negligence, gross negligence, strict liability or breach of contract. The manufacturer declines all responsibility for damage to persons, things or animals arising from the failure to comply with the norms contained in this manual. The manufacturer reserves the right to make modifications at anytime to the models while maintaining the main characteristics described herein. The manufacturer also declines all responsibility for any errors in compiling this manual.

WARRANTY PERFORMANCE: During the warranty period, a product with a defect will either be repaired or replaced after the product has been inspected by an LEM Service Technician. **LEM RESERVES THE RIGHT TO REFUSE WARRANTY PERFORMANCE OR PRODUCT EVALUATION UNLESS THE ORIGINAL SALES RECEIPT OR THE WARRANTY CARD IS ON FILE.** The repaired product will be in warranty for the balance of the five year warranty period. No charge will be made for such repair or replacement.

IMPORTANT NOTICE: If any parts are missing or defective, please contact our Customer Service Department for assistance at 877-536-7763 (M-F 8:30 am to 4:30 pm EST). **DO NOT RETURN TO THE STORE WHERE THE PRODUCT WAS PURCHASED.** LEM Products is not responsible for, or will not cover under warranty, missing or damaged parts on discounted/clearance, resale or final sale items where the seller may not be able to guarantee full functionality or completeness of the unit.

LEM PRODUCTS MERCHANDISE RETURN POLICY WARRANTY SERVICE: To obtain service under terms of this warranty, please contact us at 877-536-7763 to obtain authorization prior to returning the merchandise. No merchandise will be accepted without prior authorization. Prior to returning the product for warranty repair the product must be thoroughly cleaned and free from any food particles or other debris. Failure of the purchaser to comply with this standard may result in the unit being returned without repair. In some cases, a \$50 cleaning surcharge may apply. Please return the product prepaid in the original packaging if possible, enclose a copy of your receipt, (keep a copy of your proof-of-purchase for your records) and include a written explanation of the issue. Ship to LEM Products, 4440 Muhlhauser Road, Suite 300, West Chester, OH 45011. LEM Products is not responsible for damage incurred in shipping, make certain to pack product properly. Return shipping charges are the responsibility of the purchaser. Packages returned to LEM should be insured for the value of the product to cover any damages that may occur during shipping.

Revised February 28, 2023

NOTES

- Keep fingers out of the throat of the grinder head or serious injury may occur! Use provided stomper — not fingers — to push meat into the throat of the grinder head. Only use grinder with meat pan in place.
- Do not use fingers to scrape food away from the grinding plate while the grinder is running; doing so may cause injury.
- When in use, grinder motor will heat and may become warm to touch. To avoid injury, allow appliance to cool before moving, before putting on or taking off parts, and before cleaning and storing.

Electrical Safety Information

- For your safety, this grinder is equipped with a 3-pronged, grounding plug and must be plugged into a properly grounded outlet. Do not cut off the third (grounding) prong. Do not use an adapter.
- Arrange the power cord so that it will not drape over the countertop or tabletop, contact sharp edges, or touch hot surfaces or where it can be pulled on by children or tripped over unintentionally. Do not operate it with a damaged cord or plug.
- The appliance must be connected to a dedicated 110/120V AC electric supply only. To turn it on, first plug appliance into electrical outlet then turn the appliance on. Turn appliance off and remove plug from outlet when not in use.
- To protect against the risk of electrical shock, never immerse the appliance in water or expose it to rain or moisture. Do not use the appliance if you are standing on a wet floor. Do not operate this appliance with wet hands or bare feet. IF GRINDER FALLS INTO WATER, REMOVE PLUG FROM WALL SOCKET before attempting to remove the appliance from the water. If submergence occurs, have the appliance examined by an authorized technician before use.
- Never unplug by pulling on the power cord; always pull directly on the plug itself.
- DO NOT attempt to repair or adjust any electrical or mechanical functions on this appliance without contacting a LEM Products repair technician toll-free at (877) 536-7763 M-F 8:30 am to 4:30 pm EST or email contactus@lemproducts.com. Doing so will void warranty. Servicing must be performed as directed by qualified personnel only.

The warnings and instructions discussed in this instruction manual cannot cover all possible conditions or situations that could occur. It must be understood by the operator that common sense must be supplied by the operator. Remember your personal safety is your responsibility.

CONTENTS

Important Safety Information 2,3
 Table of Contents 3
 Parts and Simplified Schematics 4
 Getting Started and Assembly 5
 Usage: Grinding Meat 6
 Usage: Stuffing Sausage 7
 Clean-up and Care 8
 Storage, Circuit Breaker Information, Specifications, and Attachments 9
 Tips and Troubleshooting 10,11
 Parts and Expanded Schematics 12,13
 Notes 14
 Warranty Information 15

PARTS

BIG BITE® ELECTRIC MEAT GRINDERS MODEL #1781, 1782

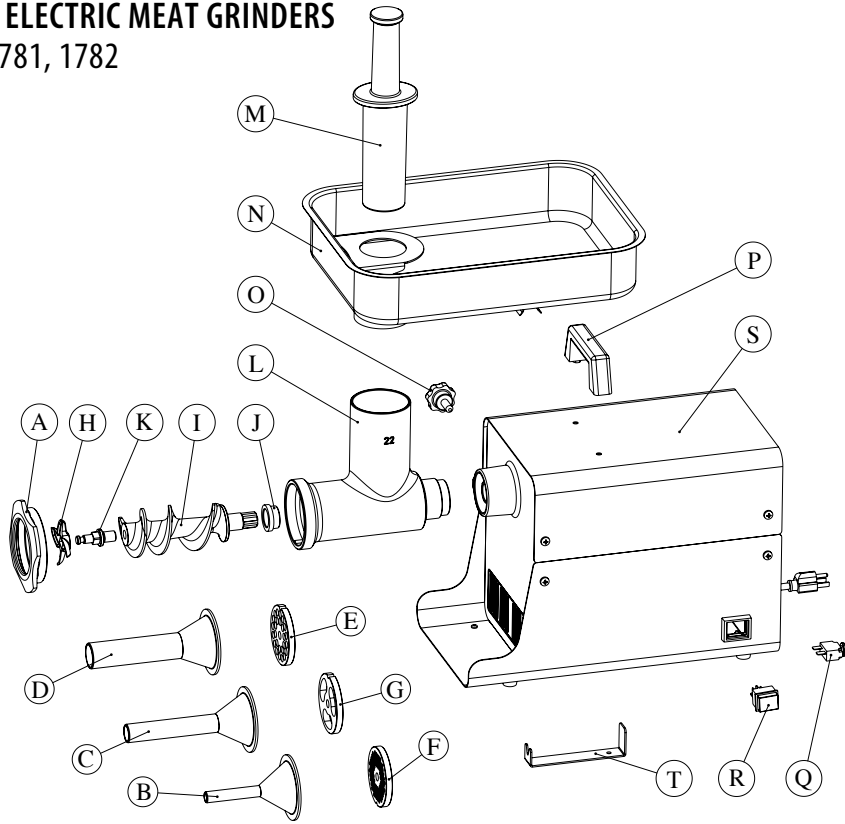

	DESCRIPTION	QTY	K		QTY
			K	Auger Stud	1
A	Retaining Ring	1	L	Grinder Head	1
B	Stuffing Tube SM.	1	M	Stomper	1
C	Stuffing Tube MED.	1	N	Meat Pan with Guard	1
D	Stuffing Tube LG.	1	O	Star Bolt	1
E	10mm Plate	1	P	Handle	1
F	4.5mm Plate	1	Q	Circuit Breaker	1
G	Stuffing Plate	1	R	On/Off Switch with Cover	1
H	Knife	1	S	Grinder Motor	1
I	Auger	1	T	Auger Puller	1
J	Auger Bushing	1	U	Bushing Removal Tool**	1

** Not Shown

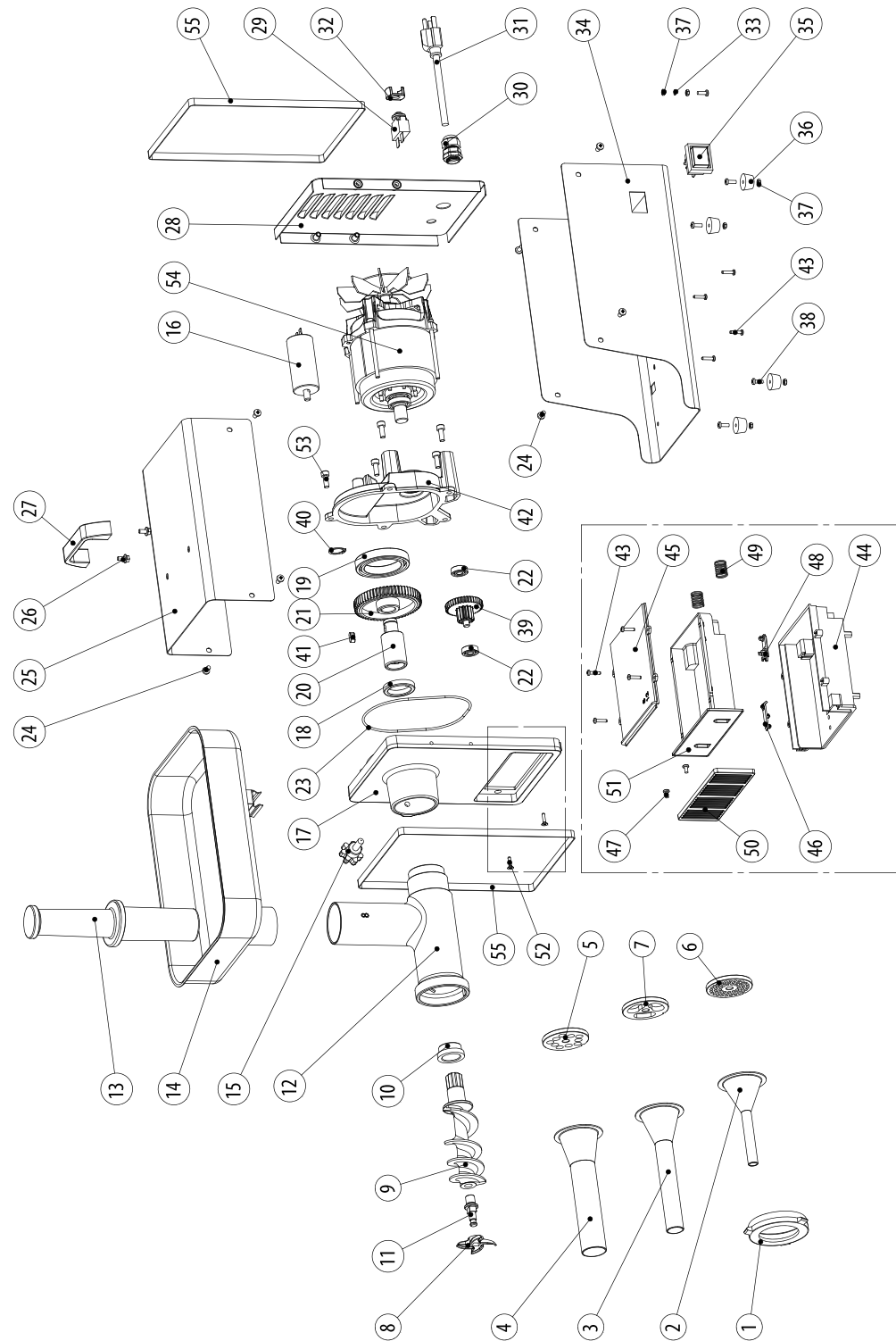

PARTS

GETTING STARTED

BIG BITE® ELECTRIC MEAT GRINDERS

MODEL #1781, 1782

#	DESCRIPTION	QTY	29		
				Circuit Breaker	1
1	Retaining Ring	1	30	Fastener for the Power Cord	1
2	Stuffing Tube SM.	1	31	Power Cord	1
3	Stuffing Tube MED.	1	32	Circuit Breaker Bushing	1
4	Stuffing Tube LG.	1	33	Spring Washer	1
5	10mm Plate	1	34	Lower Housing	1
6	4.5mm Plate	1	35	Switch with Cover	1
7	Stuffing Plate	1	36	Plastic Feet	4
8	Knife	1	37	Hex Nut for Feet	6
9	Auger	1	38	Phillips Screw M4 for Feet	5
10	Auger Bushing	1	39	Dual Gear	1
11	Auger Stud	1	40	Clip Spring	1
12	Grinder Head	1	41	Flat Key	1
13	Stomper	1	42	Front Panel of Motor	1
14	Meat Pan with Guard	1	43	Screw 2	8
15	Star Bolt	1	44	Drawer Frame	1
16	Capacitor	1	45	Drawer Cover	1
17	Front Panel	1	46	Stop	1
18	Grease Seal	1	47	Screw 3	2
19	Bearing	1	48	Pawl	1
20	Splined Drive Shaft	1	49	Spring	2
21	Gear	1	50	Drawer Panel	1
22	Bearing 2	2	51	Drawer	1
23	O-ring	1	52	Screw 4	2
24	Screw 1	8	53	Screw 5	5
25	Upper Housing	1	54	Motor	1
26	Handle Screw	2	55	1mm-thick 3M Tape 2	2
27	Handle	1	56	Auger Puller* **	1
28	Back Panel	1	57	Bushing Removal Tool**	1

* not included in #5 Grinder (1777) **Not Shown

1. Take grinder and all parts out of the box.
2. Familiarize yourself with all parts.
3. BEFORE FIRST USE: Wash all parts of the head assembly in hot, soapy water. Hand dry. This will remove any grease residue and dirt left from the manufacturing process. Do not put parts in dishwasher.

WARNING! Tie back loose hair and clothing to prevent them from getting caught in moving parts and causing injury. Remove neckties, rings, watches or other jewelry before operating the grinder.

WARNING! Never use the meat grinder without the meat pan installed. Serious injury may occur. Never remove meat pan when grinder is in use or when motor is running.

WARNING! DO NOT remove the meat pan guard; it is there for your safety. DO NOT operate the grinder without the meat pan guard in place due to the risk of serious injury; doing so may also void your warranty.

WARNING! Extreme caution must be used if meat grinder is used in conjunction with a foot switch (available at LEMProducts.com). Place foot switch out of walkway and ALWAYS TURN THE GRINDER OFF AND UNPLUG WHEN NOT ATTENDED. DO NOT USE THE FOOT SWITCH WITH CHILDREN AROUND. Extreme injury is possible. Take extra care when foot switch is in use.

ASSEMBLY

Properly assemble the grinder before use.

Refer to Parts List and Diagram on pages 4-5 for assembly.

1. Place grinder motor on sturdy, flat surface that is capable of holding its weight.
2. Inspect grinder head to ensure bushing is installed in the back of the head (see page 8, Bushing Instructions).
3. Prior to each use, lubricate bushing with food-grade lubricant (available at LEMProducts.com).
4. Insert grinder head into motor and tighten star bolt.
5. Insert auger into grinder head. Turn it until it is fully engaged, lining up the drive on the back of the auger with the motor drive.
6. Place knife on square on auger stud with cutting edge facing out.
WARNING! Knife is sharp. Handle with extreme care.
7. Place grinding plate (10 mm for first grind or 4.5 mm for a finer, second grind) on pin of auger stud in front of knife.
WARNING! Grinding plates are sharp. Handle with extreme care.
Line up notch on the plate with pin in bottom of head. Cutting edge of knife should be facing out and flush against grinding plate. When properly assembled the plate will stick out past the end of the head by $1/8''-3/16''$. If this is not the case, check Tips and Troubleshooting section. (Pages 10-11).
8. Screw retaining ring onto head until hand tight. Do not over tighten. Overtightening will cause undue wear to the knife, plate and bushing.
9. Insert meat pan into top of throat of grinder head and secure it by snapping the clip onto the handle of the motor.

Note these cautions that may harm your grinder:

1. The appliance must be connected to an 120V AC electric supply only.
2. Do not let the cord hang over edge of table or counter, contact sharp edges or touch hot surfaces.
3. Never unplug by pulling on the power cord, always pull directly on the plug itself.
4. Do not run grinder without meat in the head; severe damage to the grinder could result.
5. Use grinder on a level, stable surface to prevent tipping. Never move the grinder while in use.
6. Do not use the grinder to grind hard frozen foods, non food items or hard bones. The #22 and #32 grinds is approved for grinding soft bones such as raw chicken bones.
WARNING! Splintered bones can get into the digestive tract of a pet and cause severe damage, or even death by puncturing the walls of the intestines or the stomach.
7. The manufacturer declines any responsibility in the case of improper use of this product. Improper use of this product voids the warranty.

USAGE: GRINDING MEAT

TIPS AND TROUBLESHOOTING

WARNING

Never use the meat grinder without the meat pan with guard installed. Serious injury may occur. Always unplug grinder before walking away, maintenance or clean-up.

Never remove meat pan when grinder is in use or motor is running.

NEVER USE FINGERS TO PUSH MEAT INTO THE HEAD! Serious injury may occur. Use the supplied meat stomper only!

The appliance is designed for domestic use and not for commercial purposes.

Pull up hair and lose clothing, remove neckties and jewelry.

Before GRINDING:

1. Remove all tendons, bone, sinew, and skin from meat.
2. Cut meat into strips that will easily fit into throat of the grinder head of grinder.
3. It is highly recommended to grind meat twice.
4. Meat should be chilled in freezer prior to first grind and second grind, and periodically as needed during grinding.
5. Fully assemble grinder, including meat pan, prior to plugging it in.

FIRST GRIND:

1. Place meat in freezer or refrigerator for 15-20 minutes prior to grinding. Meat that is 40°F or colder (but not frozen) will grind best.
2. We recommend using the 10 mm Grinding Plate for the first grind and the 4.5 mm plate for the second grind.
3. Take chilled meat from freezer or refrigerator and put into meat pan.

WARNING! Never use the grinder without the meat pan with guard in place.

4. Always keep the meat stomper within reach for use when grinding.
5. Plug the grinder into the electrical outlet. The appliance must be connected to an 120V AC electric supply only.
6. Stand on the side of the grinder that has the on/off button, for quick access, in case a safety issue arises.
7. Turn on the grinder and feed meat strips in only as fast as the grinder will take them. Do not overload or overfill the throat of the grinder head. Let the grinder do the work. Don't force meat using the stomper; use the stomper to guide the meat into the throat of the grinder head.

WARNING! Never scrape meat from the grinder plate with fingers. Injury is likely.

8. If clog occurs, use the meat stomper to push meat down to the auger to clear the throat of the grinder head. Resume feeding the meat, but feed it more slowly. If clogging continues, see tips and troubleshooting on page 10.
9. When grinding is complete turn off grinder and unplug from electrical outlet.

SECOND GRIND:

1. Return ground meat to the freezer or refrigerator (15-20 minutes) to return to 40°F or colder (but not frozen) for the best grind.
2. With the grinder off and unplugged, remove the meat pan and grinder head and disassemble. Remove and thoroughly clean all parts.
3. Reassemble the grinder using the 4.5 mm grinding plate and replace the meat pan. (Refer to washing instructions on page 8 and assembly instructions on page 5).
4. Plug in and turn on the grinder. Slowly feed the ground meat into the throat of the grinder head. Do not overload or overfill the throat of the grinder head. Let the grinder do the work. Don't force meat using the stomper; use the stomper to guide the meat into the throat of the grinder head.
5. If clog occurs, use the meat stomper to push meat down to the auger to clear the throat of the grinder head. Resume feeding ground meat, but feed it more slowly. If clogging continues, turn off grinder and unplug from outlet. Disassemble grinder head, remove any tendons or silverskin from around the knife and wash out the grinder head with hot, soapy water. Reassemble the grinder fully with meat pan with guard installed, plug it back in and start again. If clogging continues, see tips & troubleshooting on page 10.

PROBLEM	SOLUTION
Grinder will not turn on	Ensure plug is fully inserted in the electrical outlet. Try a different outlet.
	Circuit breaker has popped. Follow instructions on page 9 to reset circuit breaker.
	If the appliance fails to operate, contact LEM Products technical assistance Toll Free at 877-536-7763. 8:30 am - 4:30 pm M-F EST.
Wild game burger or sausage is dry after it is cooked	Add at least 20% pork fat to your blend when grinding.
Meat is clogging the grinder throat of the grinder head	Cut meat into strips that will easily fit into the throat of the grinder head and only feed as fast as the grinder will take the meat.
	Ground meat should be trickled into the throat of the grinder head only as fast as the grinder will take the meat.
	Use the meat stomper to clear the throat of the grinder head.
	Disassemble the grinder head assembly and clean in hot soapy water. Remove all tendons and sinew from the grinder knife.
	Knife and/or plate is dull; replace both.
Grinder is not running properly or is loud	Grinder is cold. Put grinder in warm location prior to use and allow to come to room temperature. The grease inside the motor is thick viscosity and is self-lubricating and needs to be warm to properly lubricate the gears.
There is a gray substance/residue in ground meat	Plates and knife are wearing on each other; this is normal until plate and knife are married. Pinch off and discard discolored meat.
	Retaining ring is too tight, and causing excess wear on the plate; back off retaining ring a quarter of a turn. Pinch off and discard discolored meat.
	Plates and knife need to be lubricated. Spray with a food grade oil prior to grinding (available at LEM Products).
	Always marry and keep plate and knife together, and replace at the same time.
I see rust on my plate and knife	Plates and knife were not properly dried after cleaning. Wash in hot soapy water and dry immediately.
	Always dry completely by putting in a 200°F oven for 15-20 minutes after washing.
	Spray all parts with silicone spray prior to storage. Store in a dry place.
	Never wash in the dishwasher; hand wash only and dry immediately.
	Plates and knife can be stored in a bag of rice to keep moisture away from them.
If the plate is not sticking out 1/8 - 3/16" past the end of the head	The bushing is not properly installed or the bushing is too worn and needs replaced, or the plate or knife are not original parts (sold at LEM) (meaning one of both knife and plate are too thin).

TIPS AND TROUBLESHOOTING

Extreme caution must be used if meat grinder is used in conjunction with a foot switch (available at LEMProducts.com). Place foot switch out of walkway and ALWAYS TURN THE GRINDER OFF AND UNPLUG WHEN NOT ATTENDED. DO NOT USE THE FOOT SWITCH WITH CHILDREN AROUND. Extreme injury is possible. Take extra care when foot switch is in use.

Check Plates and Knives for Sharpness

Grinder plates and knives will dull over time. The product being ground and how often you use your grinder will determine how often they will need to be replaced. LEM highly suggests replacing both the knife and plate at the same time to get maximum performance.

How to tell if the plate/knife are dull and need replacing: Carefully run your thumb over the holes of the plate. If they are sharp you will feel a tugging on your skin. If you don't feel tugging the plate is dull and you should replace the plate along with a new knife. Always use the same knife and plate together, keeping them married for the ultimate grind. **NEVER RUN YOUR FINGERS OVER THE KNIFE EDGES!**

If logging occurs or performance slows:

1. Prior to grinding, and periodically throughout grinding session, chill the meat to 40°F.
2. Turn off grinder and unplug.
3. Disassemble grinder head and remove any meat, tendons or sinew that may be hindering the grinder's function.
4. Clean the grinder plate of fat and residue.
5. Replace knife and plate, then reassemble the head.
6. Resume grinding.

DO NOT operate if cord or plug are damaged, if the appliance malfunctions, if it has been damaged in any way, or if it has been immersed in water. Contact LEM Products toll-free: (877) 536-7763 M-F 8:30-4:30 EST or email Contactus@lemproducts.com

PROBLEM	SOLUTION
Meat is smearing or not extruding in strings	Knife and/or plate is dull; replace both.
	Meat is not cold, chill meat to 40°F.
	Chill grinder head assembly and meat pan to assist in keeping meat cold.
	Knife is not installed or installed backwards.
Meat is cooking on the back of the auger	Bushing is not installed or has excess wear. Replace the bushing.
	Retaining ring is too tight; screw on hand tight and back off a quarter of a turn.
	Grinder is overheating; turn off and allow grinder to cool for 20 minutes.
Grinder has stopped	Spray bushing in the back of the head with food grade lubricant.
	Motor has overheated and circuit breaker has popped. Follow instructions on page 9 to reset circuit breaker.

USAGE: STUFFING SAUSAGE

There are several methods for stuffing sausage with your grinder. Before you begin, review the tips and assemble the grinder for sausage stuffing. (**NOTE:** Although meat grinders can stuff sausage, their primary use is for grinding. A sausage stuffer is the best tool for this job and will give better results.) Review the general instructions. Then choose one of the methods and follow the instructions.

NOTE: Stuffing sausage with a grinder is a two-person job, one to feed the meat into the grinder, the other to work with the casings and filled sausage. Focusing on one task will make the process easier and safer.

TIPS FOR MAKING SAUSAGES

Use at least 20% fat with your meat and grind it like burger. Without adequate fat, your sausage will be dry when cooked, and will tend to crumble when cut or sliced.

Make sure the meat is well-chilled (40° F or colder, but not frozen).

Use only the finest natural casings — hog for large sausages and sheep for small, breakfast-style links. Rinse well and soak before use. Edible collagen casings are a nice alternative without the prep.

GENERAL INSTRUCTIONS FOR STUFFING SAUSAGE CASINGS

Pull up hair and lose clothing, remove neckties and jewelry.

1. Feed casings onto stuffing tube, making sure to leave the end of the casing open.
 2. Turn on grinder and feed meat into the head until meat is at the end of the stuffing tube.
 3. Stop grinder and pull casing out past the opening of stuffing tube about 1". Twist, knot, or dip casing closed.
 4. Restart grinder. This procedure will keep the casing from filling up with air when you first start stuffing.
 5. Continue to feed meat into the grinder head until the casing is filled. Stuff the casing firm, but not to the bursting point.
 6. To divide the sausage into links, give the casing two or three quick twists before adding more meat. Twist links in alternating directions (clockwise for the first, counter-clockwise for the second) to ensure that they keep their forms.
 7. The other option is to fill the casing into a filled rope and then twist into links. To complete this job in less time, squeeze off the first link and twist the second link away from you, skip the third link and twist the fourth link away from you again. This method you are twisting only half as many times, twisting every other sausage, and always twisting in the same direction.
 8. If air pockets form in your sausage, you can pop them with a sausage pricker or sharp, sterilized needle.
- NOTE:** Do not force meat into the throat of the grinder head faster than the auger will take it; trickle it into the head. Keep throat of the grinder head as clear as possible.

GRINDER ASSEMBLY FOR SAUSAGE STUFFING

Follow assembly instructions on p.5 #1-5

METHOD #1 Grind twice > season > stuff:

1. Grind meat with 10 mm plate. If desired, do a second grind with 4.5 mm plate for a finer grind.
2. Mix in seasoning, water, and cure (if using).
3. Unplug grinder. Remove grinding plate and knife and replace with stuffing plate (refer to Assembly instructions on p. 5).
4. Place stuffing tube (choose size to fit your casings) in front of stuffing plate and secure with retaining ring.
5. Plug in grinder and turn on. Feed meat through grinder into casings.

METHOD #2 Season meat > grind and stuff:

1. Cut meat into strips; mix with seasoning or marinate.
2. Assemble grinder using 4.5 mm plate.
3. Feed seasoned meat into the grinder.
4. Place stuffing tube (choose size to fit your casings) in front of stuffing plate and secure with retaining ring.
5. Grind directly into casings.

METHOD #3 Coarse grind > add seasonings > fine grind > stuff:

1. Grind meat with the 10 mm plate, then mix in seasonings.
2. Unplug grinder. Remove 10 mm grinding plate and replace with 4.5 mm plate (refer to Assembly instructions on p. 5).
3. Place stuffing tube (choose size to fit your casings) in front of stuffing plate and secure with retaining ring.
4. Plug in grinder and turn on. Feed seasoned ground meat through the grinder into casings.

CLEAN-UP AND CARE

DANGER

ELECTROCUTION HAZARD. DO NOT IMMERS GRINDER MOTOR IN WATER. Hand wash all removable grinder parts; do not put in dishwasher. Dry thoroughly.

Always unplug grinder before cleaning, care, or walking away.

Thoroughly hand wash all grinder parts in warm soapy water prior to use. Do not soak or use dishwasher. Always be thorough when cleaning and sanitizing components. Raw meat residue can allow bacterial growth that can cause illness or death. Dry thoroughly prior to storage. Follow USDA safe food handling instructions: <https://www.fsis.usda.gov/food-safety/safe-food-handling-and-preparation>

1. Turn off grinder and unplug from electrical outlet. DO NOT touch housing during cool down period. Housing will take a few minutes to cool down after unit is turned off. When grinder is turned off, cooling fan will no longer operate.
2. Remove meat pan from top of grinder.
3. Unscrew star bolt and remove grinder head. Disassemble grinder head assembly, including the auger bushing from the back of the head.
WARNING! Knife and plates are sharp. Handle with extreme care.
4. Hand wash each piece, including the meat pan, in hot, soapy water. Do not soak head, auger, plates, or knife. Hand dry immediately. To ensure all parts are thoroughly dry prior to storage, you can place parts in a low-heat oven (200°F) for 15-20 minutes.
5. Spray all parts with silicone spray or other food-grade lubricant prior to storage.
6. Reassemble grinder head, including the auger bushing (instructions below).
7. Be sure grinder is completely cool before storage.
8. Check plates and knife for sharpness (instructions on page 10). If they feel dull replace prior to next grinding session (replacement parts available at LEMProducts.com). Always replace knife and plate together.
9. Store knife, plates, and auger puller in the drawer in the motor housing.

AUGER BUSHING INSTRUCTIONS

REMOVAL

Tools needed: mallet/hammer and the bushing removal tool (included).

1. Remove the retaining ring, plate, knife, and auger from the grinder head.
WARNING! Knife and plates are sharp.
2. Place the threaded end of the grinder head on a flat, stable surface with the back end facing up. (Protect surface with cutting board or cloth to prevent damage.)
3. Place the bushing removal tool on the lip of the auger bushing in the back of the head.
4. Tap the bushing removal tool with your mallet until the bushing comes loose and falls out.

INSTALLATION

1. Place the auger bushing on the drive end of the auger and put it into the grinder head (refer to schematic on page 4).
2. Place the head upright on flat, stable surface with the auger and the threaded end of the head, facing up. (Protect surface with cutting board or cloth to prevent damage).
3. Tap the stud end of the auger until the bushing is fully pressed into place.
4. Reassemble the knife and plate, checking that the plate sticks out past the end of the head by approximately $\frac{1}{8}''$ - $\frac{3}{16}''$ and the retaining ring will easily thread on. If it sticks out too far, you may have to tap the bushing in further. **NOTE:** If when the head is reassembled the plate does not stick out past the end slightly, then the bushing has excess wear and should be replaced.

WARNING! Knife and plates are sharp.

STORAGE

Note: When grinder is turned off, cooling fan will not operate. Do not touch housing during cool down period. Housing will take a few minutes to cool. Wait for grinder to cool before storing.

1. Let grinder motor cool prior to storage. Thoroughly clean all parts of the grinder. Make sure all parts are thoroughly dry prior to storage.
2. Store the grinder in the upright position, preferably in the original box. Keep the product manual with the grinder.
3. Store the appliance in climate controlled environment in the upright position to extend the life of the motor.
4. If storage location is not temperature-regulated: Prior to use, bring grinder motor inside to warm up. This will make the motor run more smoothly and the grease will lubricate gears better. This will help to extend the motor life.

CIRCUIT BREAKER INFORMATION

Your LEM grinder is equipped with a circuit breaker to protect the appliance. In the event of a power disruption, abnormal operation, or overheating, the motor will temporarily shut down to prevent damage. If this should happen, follow these 7 steps, in this order:

1. Turn On/Off switch to off.
2. Unplug appliance.
3. Check inside of grinding appliance and remove any obstruction.
4. Wait 1 or 2 minutes, then plug appliance into wall outlet again.
5. Push Restart Button and release. The button is located on the circuit breaker on the back panel of grinder; see diagram on page 4.
6. Plug in grinder. Turn on/off switch to on.
7. Resume operation.

SPECIFICATIONS

Model #	Head Size	Power Rating	Horsepower
1781	22	120 Vac 60Hz 750w	1.0
1782	32	120 Vac 60Hz 1100w	1.5

AVAILABLE ATTACHMENTS (SOLD SEPARATELY)

GRINDER	SKU	50lb. Mixer (734A)	50lb. Tilt Mixer (868)	Dual Grind Attachments (1472,1473)	25lb. Mixer (733A)	25lb. Tilt Mixer (869)	Patty Maker (887)	Ground Meat Packing System	Jerky Slicer/Tenderizer (433T)	Patty, Jerky & Snack Stick Maker (517)	Foot Switch (724)	Juicer (1227)
#5	1777								✓	✓	✓	✓
#8	1778			✓	✓	✓	✓	✓	✓	✓	✓	✓
#12	1780	✓	✓	✓	✓	✓	✓	✓	✓	✓	✓	✓
#22	1781	✓	✓	✓	✓	✓	✓	✓	✓	✓	✓	✓
#32	1782	✓	✓	✓	✓	✓	✓	✓	✓	✓	✓	✓